

Installation Instructions for 40W and 27W Projector Lamp

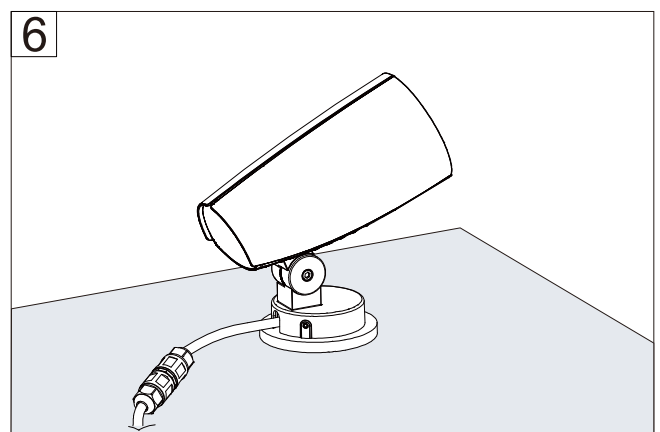

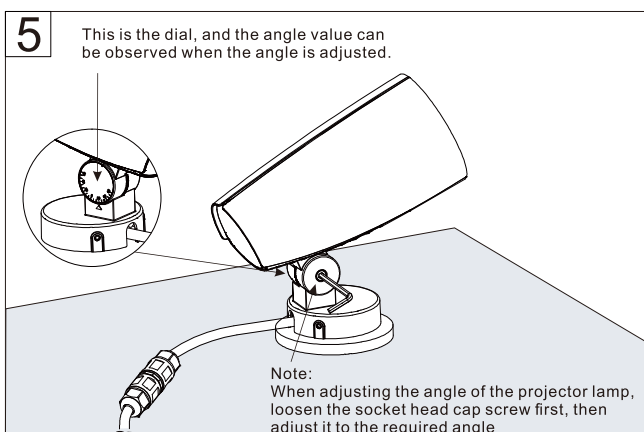

Installation Instructions for 40W and 27W Projector Lamp (with earth spike)

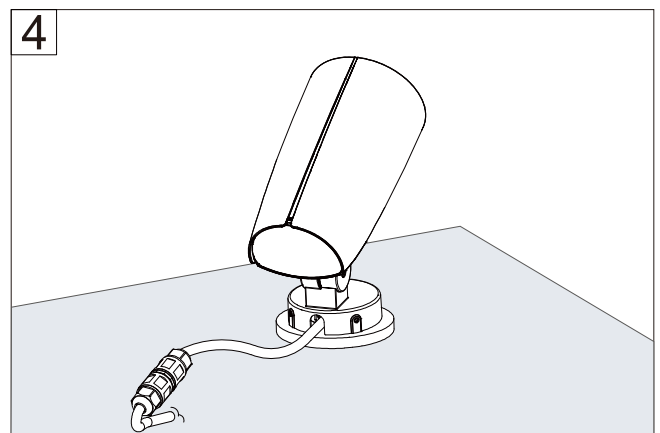
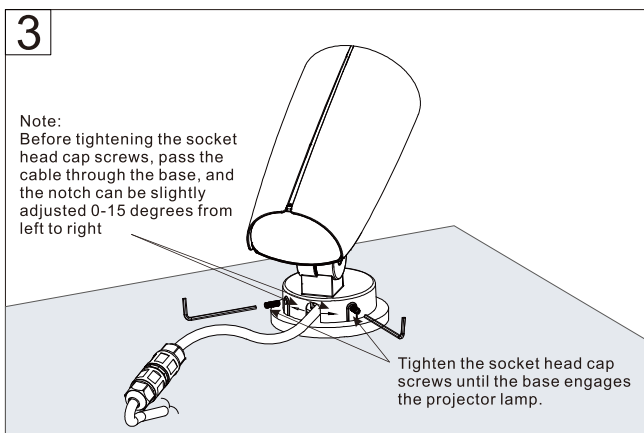
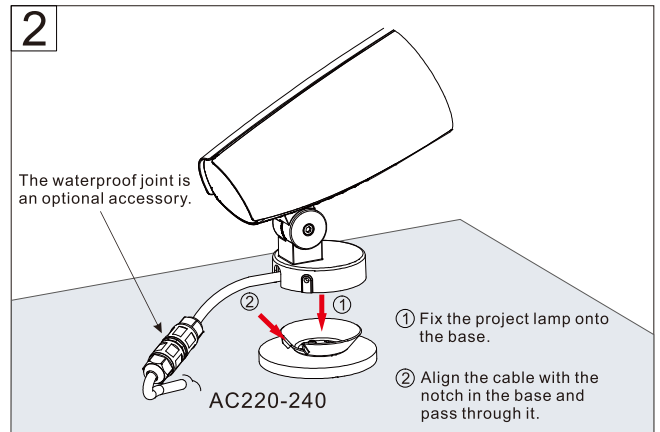
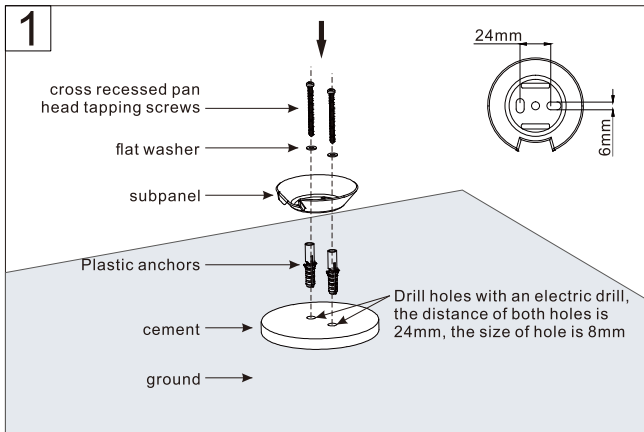
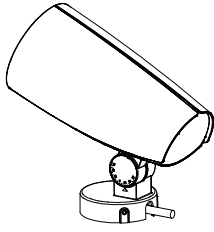